

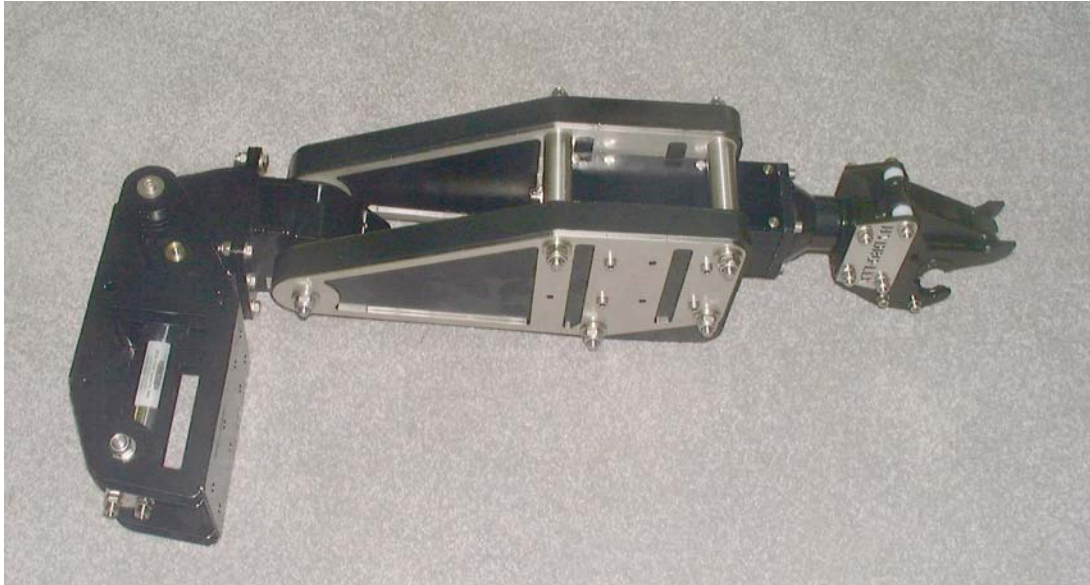

HYDRO-LEK

REMOTE HANDLING SPECIALISTS



HLK-RHD4 Manipulator:

The HLK-RHD4 Manipulator is a heavy duty, rugged four-function arm. It incorporates the HLK-2020 Continuous Jaw Rotate Mechanism which also has the unique 19mm diameter rope cutter. The arm incorporates a flange mounting to facilitate port or starboard mounting configurations on the slew plate. The slew plate is designed to enable the arm to swing across the front of the vehicle and also 30° to the outside. The arm also uses the larger HLK-13020 Hydraulic Cylinders to give additional lifting capability.

Specification:

Dimensions	Length of arm	785mm
	Length of slew plate	320mm
	Height (Stowed)	717mm
	Width	190mm
Capacities	Rotate	360° continuous
	Torque at 140 bar (across ports)	38Nm
	Lift capacity at full reach at 160 bar	90Kg
	Max working pressure	210 bar
Weight	Weight in air	26.5Kg
	Weight in water	18.5Kg
Construction	316 SS Epoxy hard coated	
	HE 30 Hard anodised aluminium	
	High Density Polyethylene	
Ports	1/8NPT / 7/16 S.A.E	

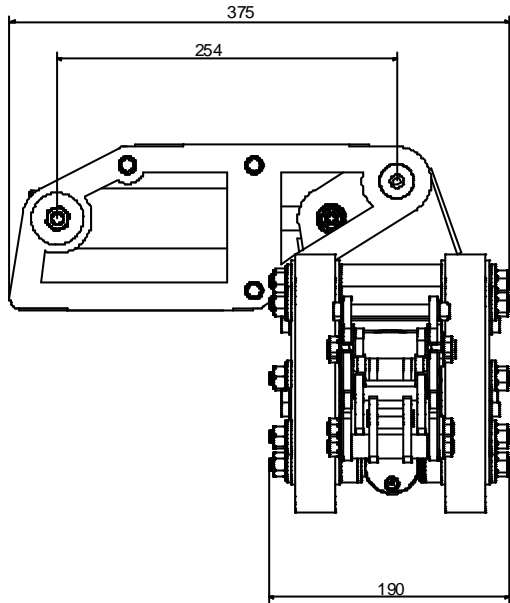

SPECIFICATION

DIMENSIONS:

LENGTH OF ARM (OPEN) 785 MM (FROM SLEW)

LENGTH OF SLEW PLATE 320 MM

HEIGHT 717 MM

WIDTH 190 MM

CAPACITIES :

ROTATE 360° CONTINOUS

TORQUE AT 140 BAR 38 Nm

LIFT CAPACITY AT FULL REACH Kg

MAX WORKING PRESSURE 210 BAR

WEIGHT IN AIR 26,5 Kg

WEIGHT IN WATER 18,5 Kg

CONSTRUCTION

316 SS EPOXY HARD COATED

HE 30 HARD ANODISED ALUMINIUM

HIGH DENSITY POLYETHELENE

PORTS:

1/8" NPT / 7/16 S.A.E.

