

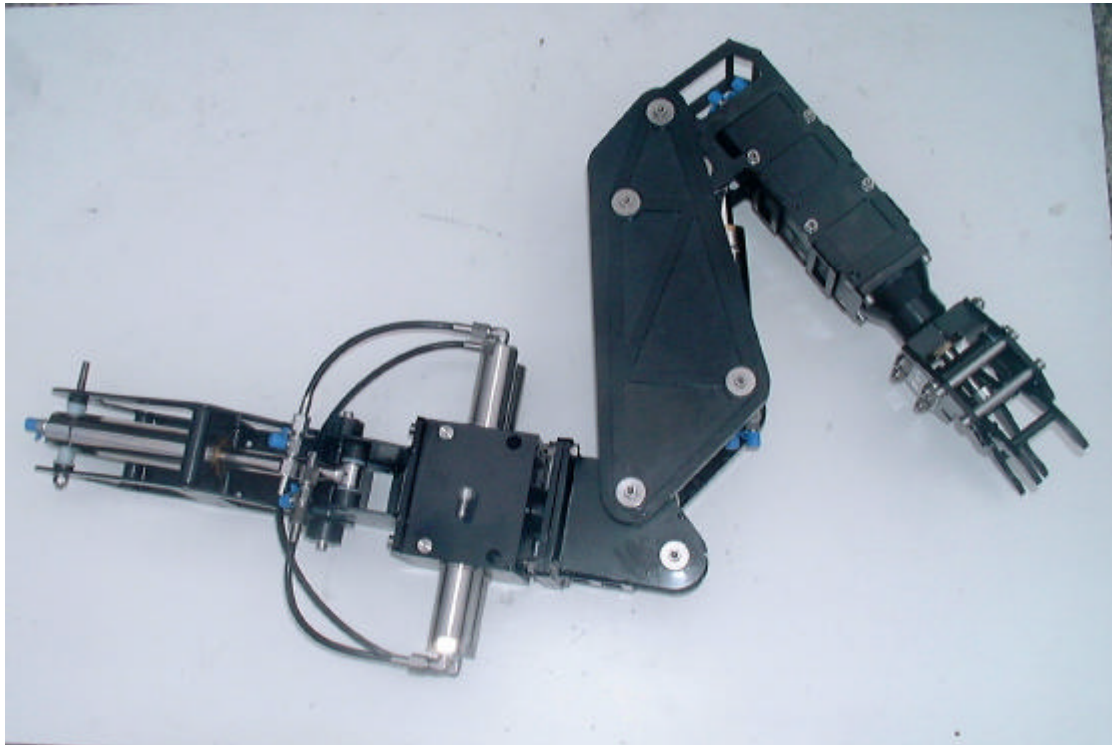

INNOVATIVE DESIGN ENGINEERING



HLK-HD6R Manipulator:

The HLK-HD6R Manipulator arm is based on the HD5, but with an HLK-2260 Rotary Actuator fitted at the shoulder joint, which is mountable in 4 separate positions to allow port & starboard mounting as well as offering additional up or down functions. It allows additional reach to gain access in holes or pipe ends.

Specification:

| | | |
|---------------------|--|-----------------|
| Dimensions | Length of arm (from slew pivot point) | 1120 mm |
| | Length of slew plate | 280 mm |
| | Height | 530 mm |
| | Width | 145 mm |
| Capacities | Rotate | 360° continuous |
| | Torque at 140 bar | 38Nm |
| | Lift capacity at full reach at 140 bar | 30Kg |
| | Max working pressure | 210 Bar |
| Weight | Weight in air | 29 Kg |
| | Weight in water | 21 Kg |
| Construction | 316 SS | |
| | HE 30 Hard anodised aluminium | |
| | High density polyethylene | |
| Ports | 1/8 NPT / 7/16 SAE | |

Hydro-Lek Ltd. Unit 4 Weller Drive Hogwood Lane Ind. Estate Finchampstead Berks. U.K. RG40 4QZ

Telephone: +44(0) 118 9736903 Fax: +44(0) 118 9736915

Web Site <http://www.hydro-lek.com> Email: enquiries@hydro-lek.com

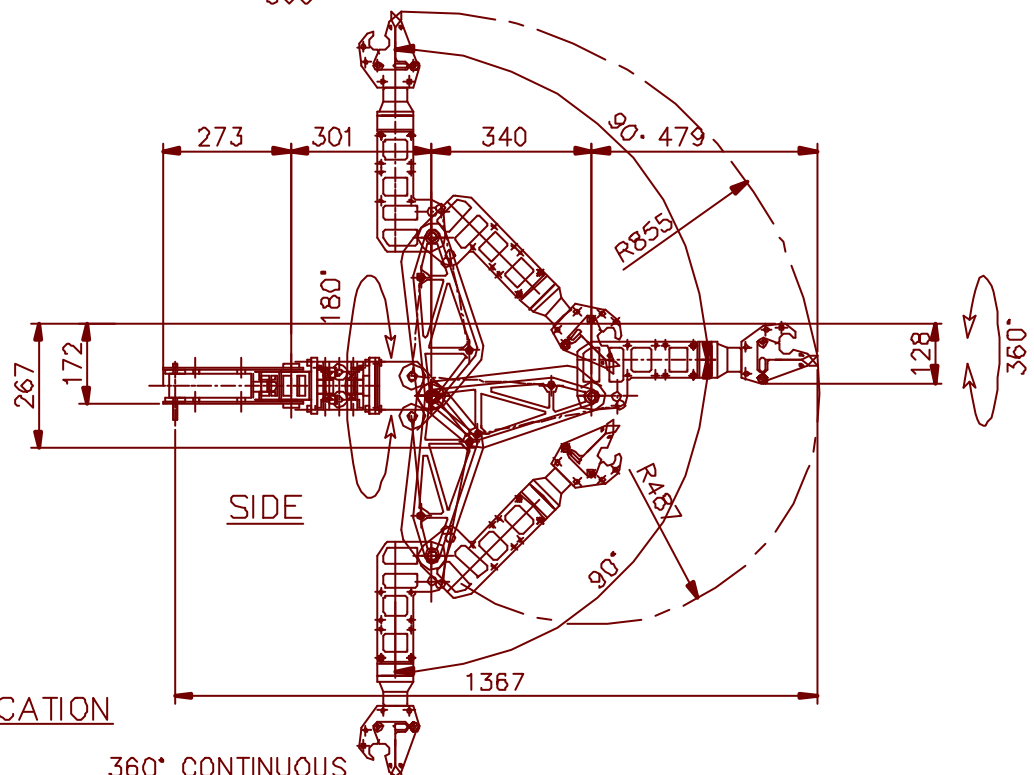
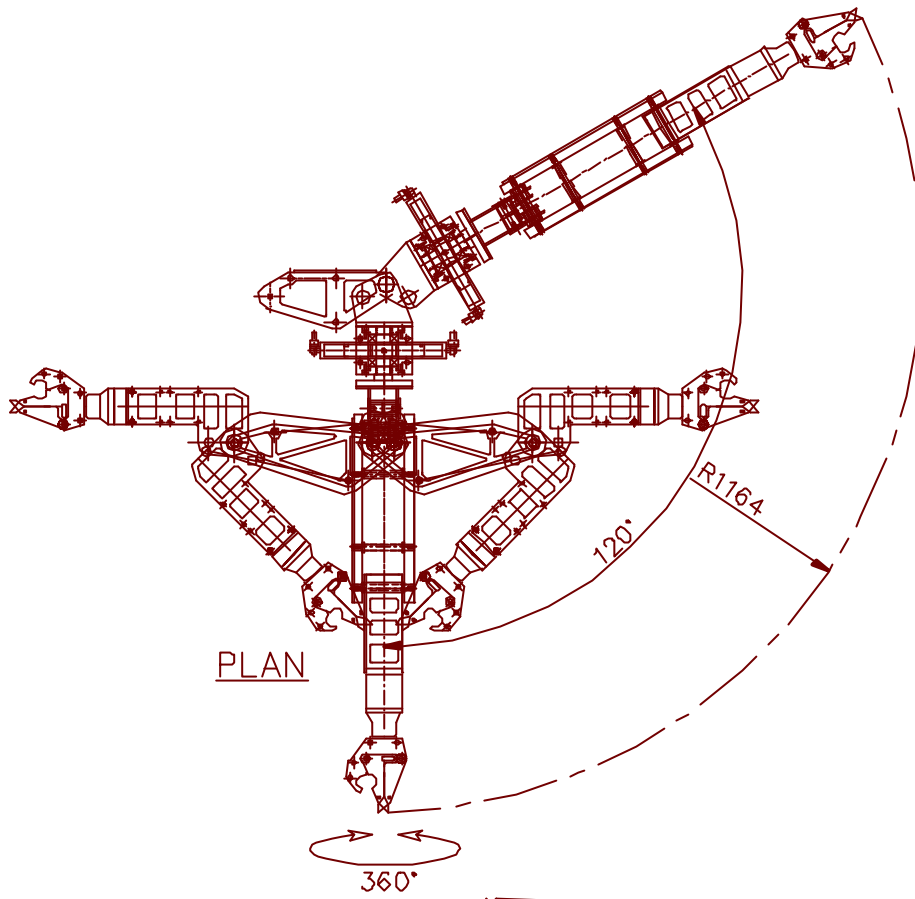

SPECIFICATION

ROTATE 360° CONTINUOUS
 TORQUE AT 140 BAR 38 Nm
 LIFT AT 140 BAR 40 KG
 MAX. WORKING PRESS. 210 BAR
 WEIGHT IN AIR 29.0 KG
 WEIGHT IN WATER 21.0 KG
 MATERIALS: - HE 30 HARD ANODISED ALUMINIUM
 316 ST. STEEL
 H. D. POLYETHYLENE
 PORTS 1/8" NPT / 7/16" SAE.

| | | |
|-------------------------|-----------|-------------------------|
| HYDRO-LEK LTD. | | HLK-HD6R MANIPULATOR |
| ISS. DATE: - | | MAT: - |
| CHKD BY - | REV NO: - | DRG. NO - CMR 5680/DATA |
| DRAWN BY: - JW 10/01/01 | | C.M. INNOVATIONS LTD. |