

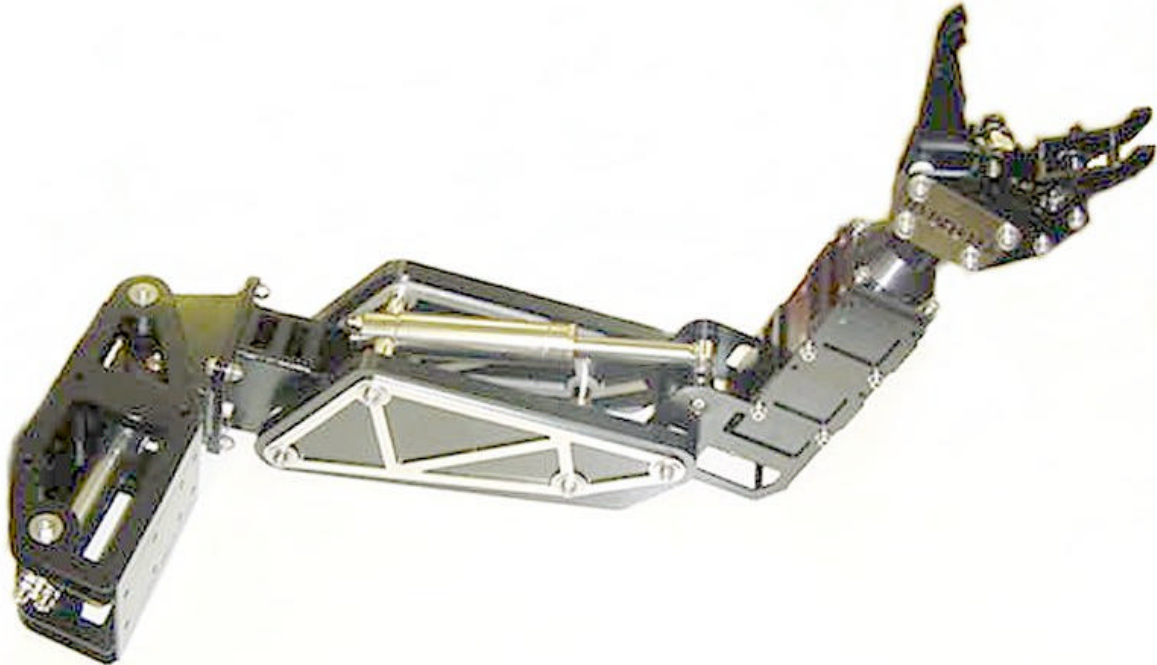

INNOVATIVE DESIGN ENGINEERING



**HLK-HD5 Manipulator:**

The HLK-HD5 Manipulator is a heavy duty, rugged five function arm designed for the new breed of smaller work class ROV's. It incorporates the HLK-2020 Continuous Jaw Rotate Mechanism which also has the unique 19mm diameter rope cutter. The arm incorporates a flange mounting to facilitate port or starboard mounting configurations on the slew plate. The slew plate is designed to enable the arm to swing across the front of the vehicle and also 30° to the outside making it also suitable as a pipe line camera platform. A rotating slew can also be used enabling the arm to be rotated through 90° from vertical to horizontal.

**Specification:**

<b>Dimensions</b>	<b>Length of arm</b>	<b>819mm</b>
	<b>Length of slew plate</b>	<b>280mm</b>
	<b>Height</b>	<b>145mm</b>
	<b>Width</b>	<b>380mm (folded)</b>
<b>Capacities</b>	<b>Rotate</b>	<b>360° continous</b>
	<b>Torque at 140 bar (across ports)</b>	<b>38Nm</b>
	<b>Lift capacity at full reach at 140 bar</b>	<b>40Kg</b>
	<b>Max working pressure</b>	<b>210 bar</b>
<b>Weight</b>	<b>Weight in air</b>	<b>21.5Kg</b>
	<b>Weight in water</b>	<b>16.5Kg</b>
<b>Construction</b>	<b>316 SS Epoxy hard coated</b>	
	<b>HE 30 Hard anodised aluminium</b>	
	<b>High Density Polyethelene</b>	
<b>Ports</b>	<b>1/8NPT / 7/16 S.A.E</b>	

Hydro-Lek Ltd. Unit 4 Weller Drive Hogwood Lane Ind. Estate Finchampstead Berks U.K. RG40 4QZ  
Telephone: +44(0) 1189 736903 Fax: +44(0) 1189 736915  
Website: <http://www.hydro-lek.com> Email: [enquiries@hydro-lek.com](mailto:enquiries@hydro-lek.com)

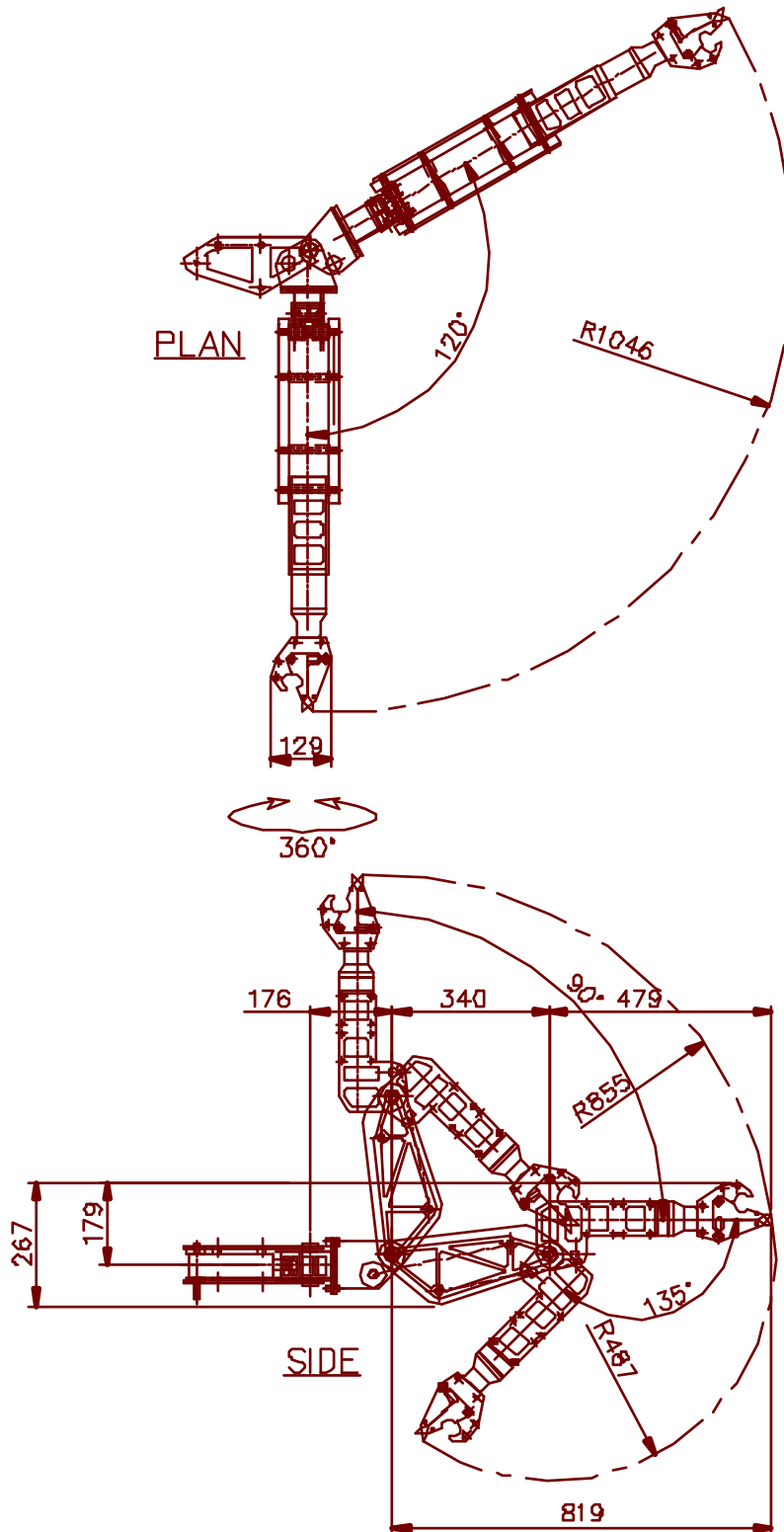

### SPECIFICATION

ROTATE	360° CONTINUOUS
TORQUE AT 140 BAR	38 Nm
LIFT AT 140 BAR	40 KG
MAX. WORKING PRESS.	210 BAR
WEIGHT IN AIR	21.5 KG
WEIGHT IN WATER	16.5 KG
MATERIALS:-	HE 30 HARD ANODISED ALUMINIUM 316 ST. STEEL H. D. POLYETHELENE
PORTS	1/8" NPT / 7/16" SAE.

HYDRO-LEK LTD.	HLK-HD5 MANIPULATOR
ISS. DATE:-	MAT:-
CHKD BY:- REV. NO:-	DRG. NO:- CMR 5600/DATA
DRAWN BY:- JW 23/8/99	C.M INNOVATIONS LTD.