

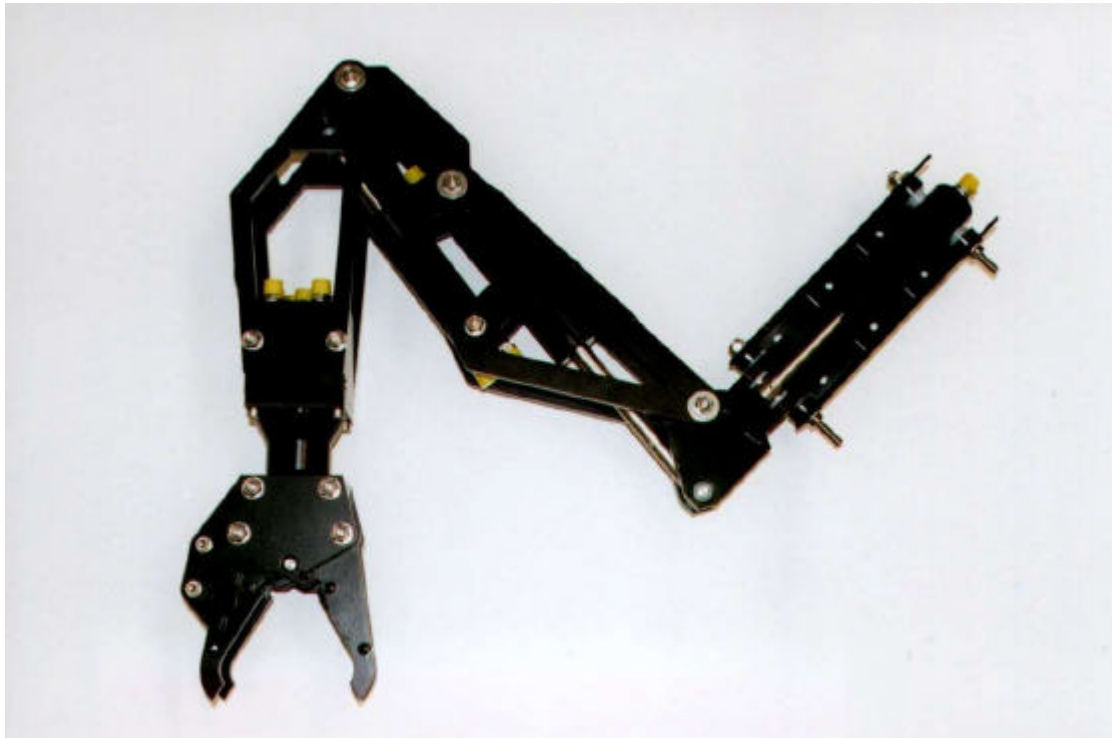

INNOVATIVE DESIGN ENGINEERING



HLK-EH5 Manipulator:

The HLK-EH5 manipulator is a medium duty work arm for the small to medium ROV. The arm is designed to mount on the slew plate within the side members of the ROV and can be handed for port or starboard mounting. As with the HLK-EH4 it incorporates the HLK-2010 series jaw actuator. The arm is ideal for deployment of probes, shackles, and cut & grab activity. Its ability to stow within the ROV frame enables it to work within cage deployed ROV systems.

Specification:

Dimensions	Length of arm	795mm
	Length of slew plate	210mm
	Height	96mm
	Width	460mm
Capacities	Rotate	180°
	Torque at 140 bar (across ports)	14Nm
	Lift capacity at 140 bar	25Kg
Weight	Weight in air	10.5Kg
	Weight in water	8Kg
Construction	316 SS	
	HE 30 Hard anodised aluminium	
	All epoxy hard coated	

Hydro-Lek Ltd. Unit 4 Weller Drive Hogwood Lane Ind. Estate Finchampstead Berks U.K. RG40 4QZ

Telephone: +44(0) 1189 736903 Fax: +44(0) 1189 736915

Website: <http://www.hydro-lek.com> Email: enquiries@hydro-lek.com

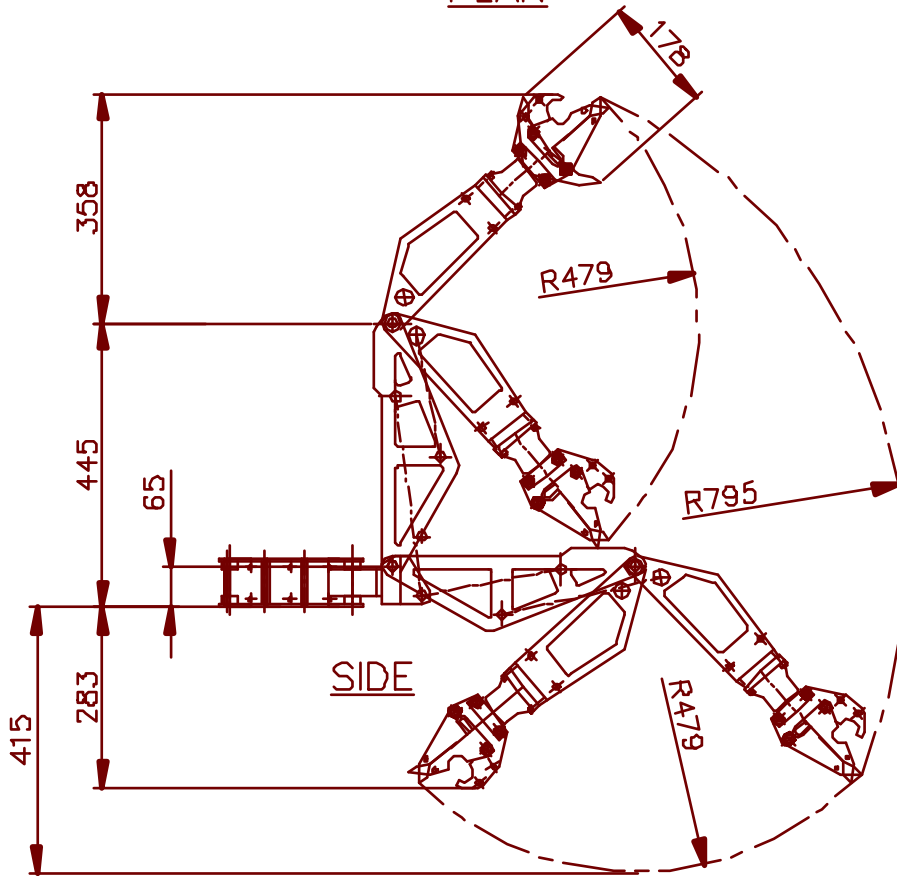
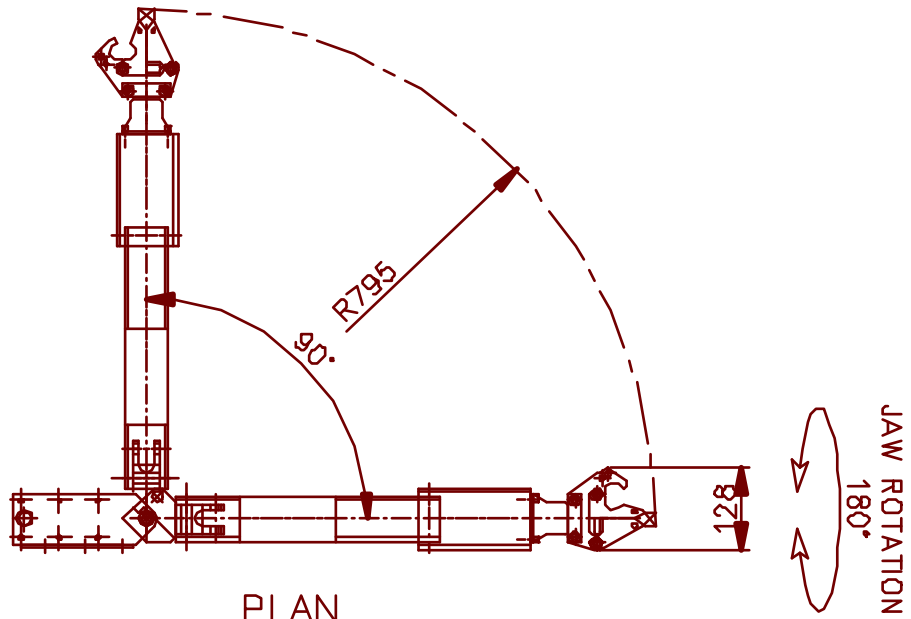

SPECIFICATION

ROTATE	180°
TORQUE AT 140 BAR	14 Nm
LIFT AT 140 BAR	25 KG
WEIGHT IN AIR	10.5 KG
WEIGHT IN WATER	8 KG
MATERIALS:-	HE 30 HARD ANODISED ALUMINIUM 316 ST. STEEL

HYDRO-LEK LTD.	HLK-EH5 MANIPULATOR
ISS. DATE. -	MAT:-
CHKD BY:- REV. NO:-	DRG. NO:- CMR 4000-5DATA
DRAWN BY:- JW 19/8/99	C M. INNOVATIONS LTD.