



INNOVATIVE DESIGN ENGINEERING



HLK-90150 Power Pack:

The HLK-90150 Power Pack is a 3-phase 4.5KW hydraulic power pack. It can be supplied with various voltage motors, typically 440 or 660V. It produces 15 litres/min at 140 BAR. The motor housing is compensated separately from the hydraulic pump to lessen the possibility of water contamination.

Specification:

Dimensions	Length	422mm
	Diameter	177mm
Weight	Weight in air	23.0Kg
	Weight in water	15.0Kg
Power	Input	3 phase 50/60Hz 4.5KW (Nom.)
	Output	140BAR at 15L/min (Typ.)
Construction		HE 30 Hard anodised aluminium

Hydro-Lek Ltd. Unit 4 Weller Drive Hogwood Lane Ind. Estate Finchampstead Berks U.K. RG40 4QZ
Telephone: +44(0) 1189 736903 Fax: +44(0) 1189 736915
Web Site <http://www.hydro-lek.com> Email: enquiries@hydro-lek.com

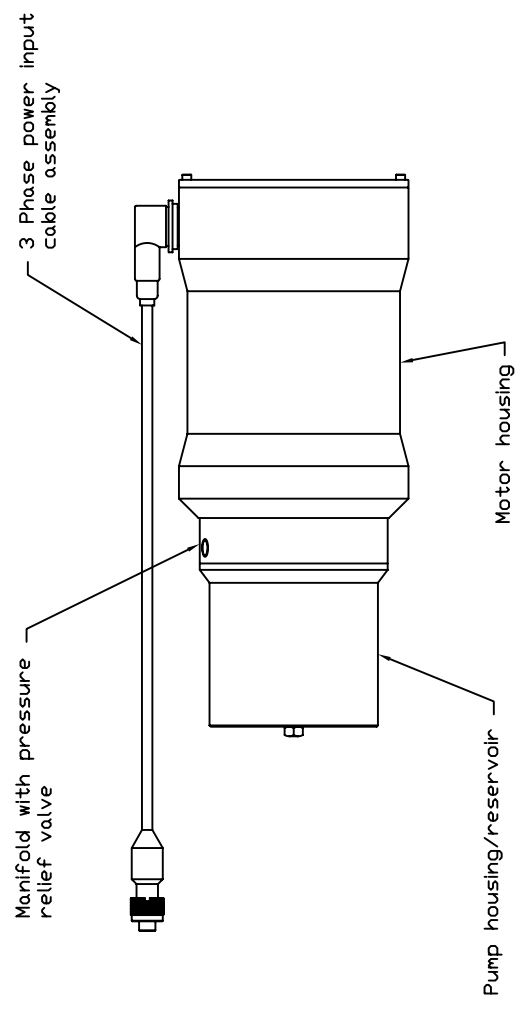
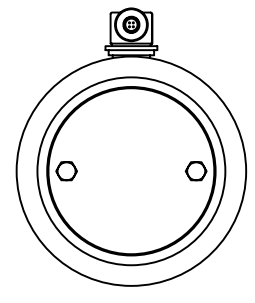
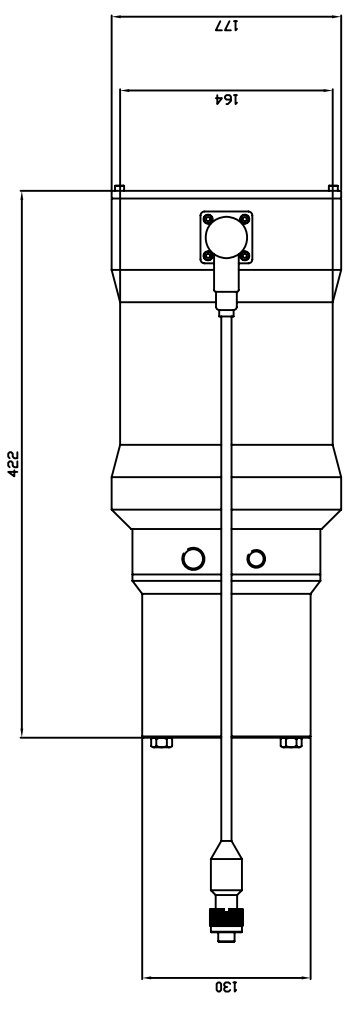

SPECIFICATION

Input: Voltage: 440 DR 660 Volt 3-Phase
 Power: 4.5kW (nom)

Output: Pressure: 140 bar (Nom)
 210 bar (Max)
 Flow: 15 L/min

Ports: 1/4" NPT Pressure
 3/8" NPT Return
 1/2" NPT Compensation

Dimensions: Length: 422mm
 Diameter: 177mm

Weight: In air: 23.0kg
 In water: 15.0kg

Materials: Aluminium alloy 6082-T6 (HE30)
 Hard black anodized

Designed by J0	Checked by	Approved by -	File name HLK 9015-A Section GA	Date 03/01/07	Scale 1:3
Hydro-Lek Limited Unit 4, Veller Drive, Hogwood Lane Industrial Estate, Finchampstead, Berks, RG40 4GZ. Tel: 0118 9736903			POWER PACK - 3ph 4.5kW MOTOR		
			HLK 90150		Sheet A3
			Edition A		8