

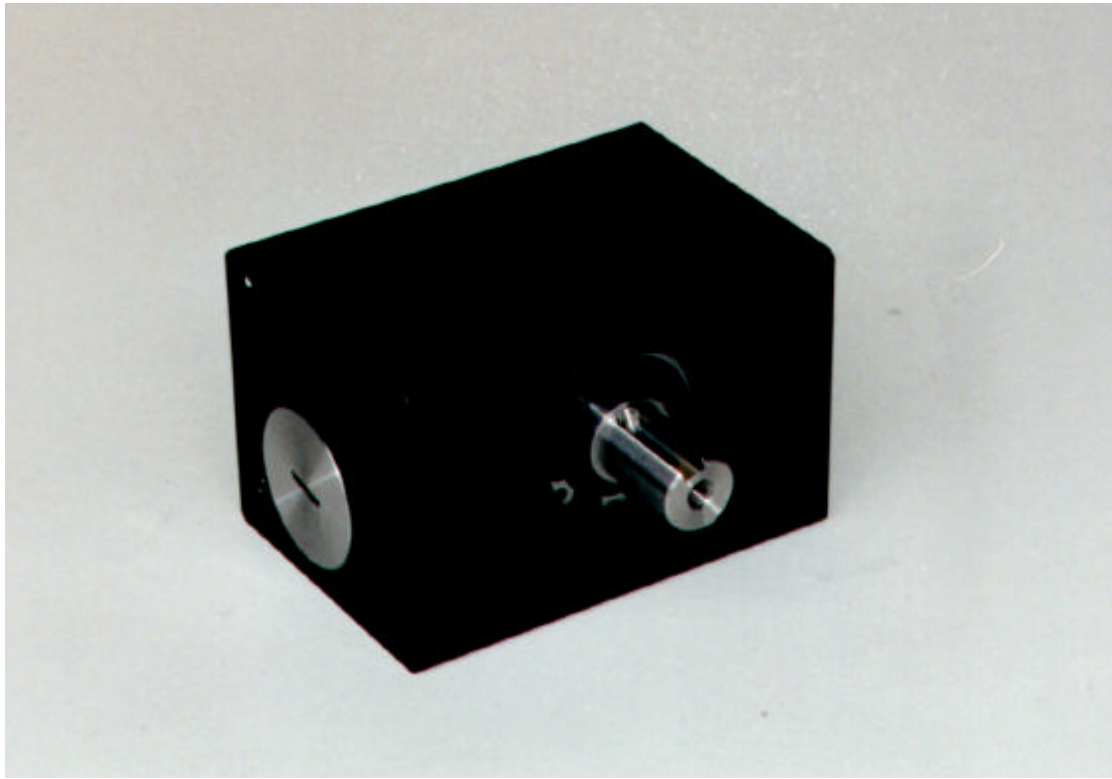

INNOVATIVE DESIGN ENGINEERING



HLK-2280 Centre Return Rotary Actuator:

The HLK-2280 Centre Return Rotary Actuator has two internally fitted heavy duty springs which return the rotate shaft to its centre position. Its small compact design, make this unit ideal for use as a remote valve actuator.

Specification:

Dimensions	Height	65 mm
	Width	100 mm
	Depth	95 mm
Function	Pan	ϕ 45°
Weight	Weight in air	2.0 Kg
	Weight in water	1.4 Kg
Material	316 SS	
	HE 30 Hard anodised aluminium alloy	
Hydraulics	Pan torque	60 NM @ 180 BAR
	Max working pressure	210 bar
Ports		1/8 NPT

Hydro-Lek Ltd. Unit 4 Weller Drive Hogwood Lane Ind. Estate Finchampstead Berks. U.K. RG40 4QZ
Telephone: +44(0) 118 9736903 Fax: +44(0) 118 9736915

Web Site <http://www.hydro-lek.com> Email: enquiries@hydro-lek.com

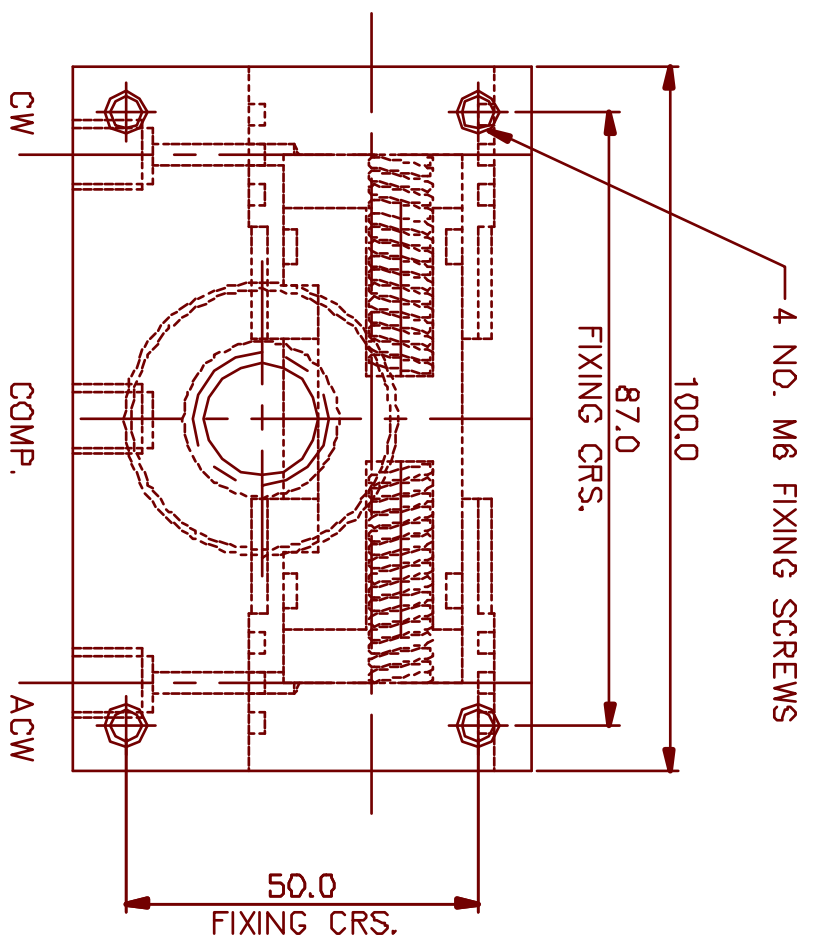
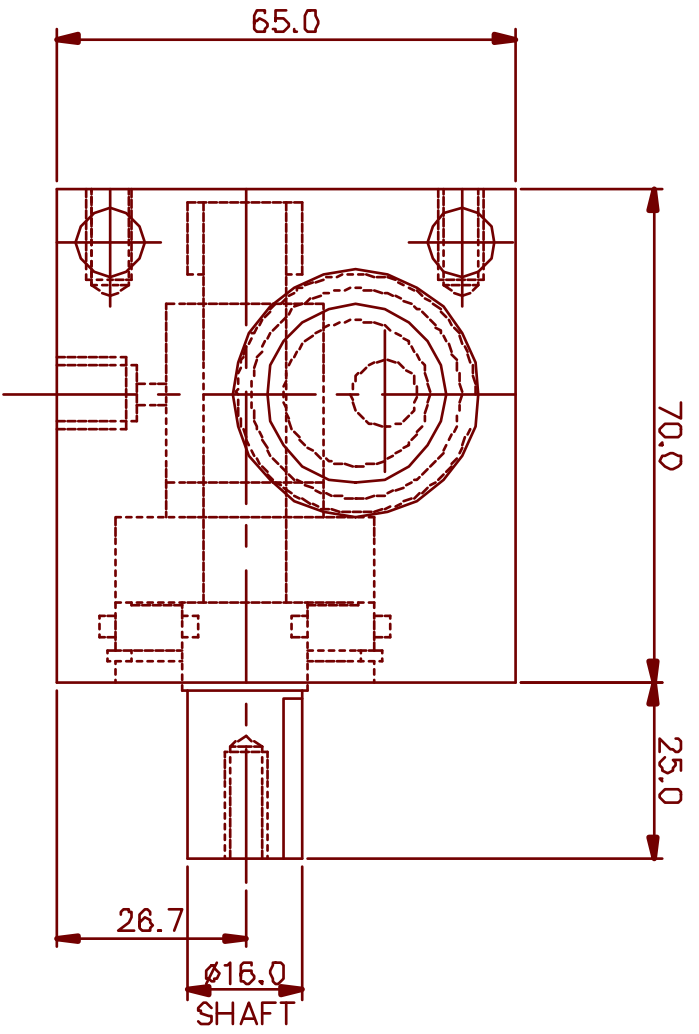

SPECIFICATION

- PAN ANGLE 45°-0-45°
- MAX. WORKING PRESS. 210 BAR
- PAN TORQUE 60Nm @ 180 BAR
- OVERALL LENGTH 100
- OVERALL HEIGHT 70 + 25 SHAFT
- OVERALL WIDTH 65
- WEIGHT IN AIR 2.0 KG
- WEIGHT IN WATER 1.4 KG
- PORTS 1/8" NPT / 7/16" SAE
- MATERIALS:- HE 30 ALUMINIUM
- 316 ST STEEL

HYDRO-LEK LTD		CENTRE RETURN ROTARY ACTUATOR	
ISS. DATE:-		MAT:-	VARIOUS
CHKD BY:-	REV. NO:-	DRG. NO:-	CMR 2280/DATA
DRAWN BY:- JW 24/3/00		C.M. INNOVATIONS LTD.	